

MERCURY2⁺

Intrinsically Safe Operator Interface

- HAZARDOUS AREAS
- HOSTILE ENVIRONMENT
- ALL WEATHERS



The Versatile Operator Interface for Hostile-areas from

The Mercury 2⁺ Terminal is the next generation of the Mercury family, designed to be fully backward compatible, whilst future proofing the long term availability of this product line. The benefits of the Mercury 2⁺ Terminal include:

- Long term availability: We offer 10 year support guarantees*
- Extended Warranties: Subtle redesign of the keyboard allows a 10 million key press or 2 year standard warranty**
- High speed Hazardous Area communications: The Mercury 2⁺ Terminal will allow 115,200 Baud communications up to 1km in the Hazardous Area
- Enhanced Processing performance: The use of a high speed RISC processor and machine independent high level language makes internal processing an order of magnitude faster, giving crisp graphic displays
- Two digital outputs are provided for gate control or other signalling purposes
- Extended Visibility: An adaptive back light is provided to ease reading in low light and dark conditions when used with the new R507 IS Communications modules
- Multiple languages are supported, including non-Roman character sets. We currently support Thai and Cyrillic with Mandarin Chinese to follow
- Security Card Adaptive Mechanism (SCAM) allows integration of new card technologies as they become available
- Currently supported security standards include, Wiegand, EM4102, HID, iClass, Mifare
- Mercury Application Programming Interface available for localisation and customisation
- Dust-proof ATEX certification available as standard

Designed for use in Hazardous Areas, the rugged construction and Intrinsically Safe certification enable it to be used in Zone 0 locations in the continuous presence of flammable vapours and gases.

The Mercury 2⁺ Terminal was designed to IP65 for outside use and can operate in temperatures from -20°C to +60°C, so it is well able to withstand extreme weather conditions and is also appropriate for areas where wash-down procedures are necessary.

Simple to install, easy to use and maintenance-free, the Mercury 2⁺ Terminal is readily interfaced to most plant control systems. The Mercury 2⁺ Terminal supports a variety of communications options, such as multi-drop, point to point, Modbus and a range of other functions. These are easily selected using a menu system and stored in password protected non-volatile memory.

The full function keypad allows the operator to enter data and commands. A beeper confirms key strokes and allows the host computer to give audible warnings.

Large and small character text can be displayed simultaneously together with graphics images on the high contrast Liquid Crystal Display.

The Mercury 2⁺ Terminal is designed for use with process computers, PLCs or other control systems capable of serial communication and operates as either a dumb terminal using a protocol similar to a standard VDU or a Modbus interface. The messages it displays and the responses to keyboard inputs are determined solely by the software in the host control system to which it is interfaced.

The Mercury 2⁺ Terminal is widely utilised in Terminal Automation Systems for truck, rail and ship loading. They are also widely used for batch processing in the pharmaceutical, weighing, LPG tank filling and process industries.

MERCURY2⁺

Using the Mercury 2⁺

IS Interface Module

The Mercury 2⁺ Operator Terminal can be used with older style R007 Interface Module as designed by Spectra-Tek or the current R507 Interface Module. When the Mercury 2⁺ Operator Terminal is used with the R507, the user benefits from the following enhancements:

- Serial communication rates can be increased up to 115,200 Baud
- More power is delivered to the Mercury 2⁺ and the adaptive backlight will give a brighter display
- The R507 saves considerable DIN rail & cubicle space

The unit provides galvanic isolation between the field mounted Hazardous Area equipment and the Safe Area 24V power and host communications. This simplifies installation and reduces cost because there is no requirement for an I.S. earth.



Connection to a Mercury Terminal in the Hazardous Area is by a simple Quad core or two pair cable, carrying power and full duplex serial data together with multi-drop control at up to 1km distance.

Standard RS232/422/485 communications are all available at the Interface Module and up to fifteen Mercury 2⁺ Terminals can be operated in a multi-drop system connected to a single serial port in the Host computer.

There are Safe Area versions of the Mercury 2⁺ Terminal in which the power and communications may be made directly to the Terminal, and RS232, RS422 or RS485 signalling standards can be chosen.

Data Protocol

The Mercury 2⁺ Terminal operates a subset of the widely used VT100 protocol, effectively emulating the top left-hand corner of a VDU screen. Modbus is a standard feature.

User Memory

7000 characters of non-volatile memory are provided into which the user may download Text or Graphics messages. Each message is assigned a number, allowing instant recall to the Mercury screen by a simple host command. Up to 99 messages may be stored separately, provided the total does not exceed 7000 characters.

Display System

Black characters are contrasted against a silver background to provide a display of exceptional definition and readability. Images may be stored in separate screen memory pages, from which combinations of text, large text characters and graphics may be controlled and mixed on the screen.

Simple graphics may be created using the Mercury 2⁺ Terminal's line and block drawing algorithms or alternatively bitmap images may be downloaded, giving direct access to the 240 x 64 pixel array. Complex graphics, created on a PC, may be downloaded to the Mercury 2⁺ Terminal using the Bitmap Graphic Converter software. Contact the factory for more details.

Two text sizes are available providing standard and large characters: standard sized characters produce 40 x 8 lines of text. There are 128 standard characters which may be supplemented by a further set of 96 user definable characters, allowing special language or symbols.

Keyboard

The Mercury 2⁺ Terminal can be ordered with one of a range of commonly supplied keyboards and we also offer a full customising service, allowing between 1 and 42 keys and customised graphics. The standard

keyboard uses an array of 30 membrane buttons whose domed surfaces give a tactile feel. The use of the shift key allows for upper and lower case alphanumeric characters and numerics. Eight of the keys may be assigned special functions, such as Batch Start. An audible beeper sounds for each keystroke and is mounted behind the membrane, which it uses as a diaphragm. The beeper also signals a successful card read.

For further information on customised keyboards, please contact the factory.

Configuration

The Mercury 2⁺ Terminal is simply configured through the keyboard in a password-protected set-up mode. The configuration is stored securely in non-volatile memory. There is a choice of set-up language available.



Options

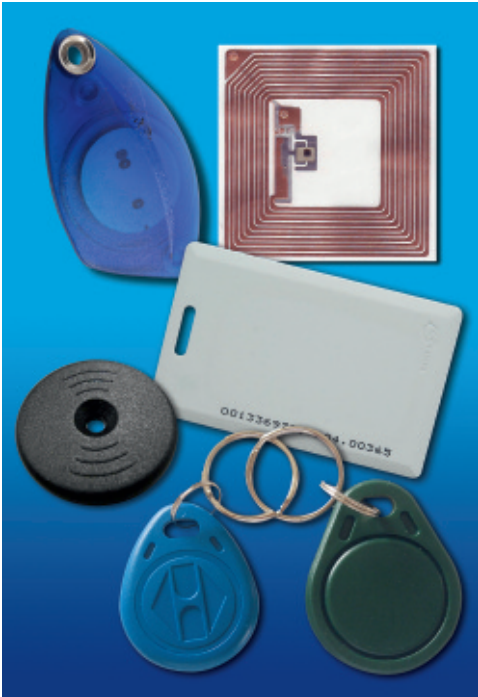

IS Proximity Card

The Mercury 2+ can be equipped with a range of RFID readers including the 125KHz EM, Hitag 1/S, Hitag 2 and HID ProxCARD II as well as the 13.56MHz MIFARE, I-CODE and iCLASS standard readers.

Tags & Cards

The readers can be used with ISO (credit card size) cards or clamshell card designs with a slot for a lanyard as well as a range of durable Tags and Keyfobs.

IS Contact Inputs

Three inputs are provided to read external dry contacts such as push-buttons, proximity detectors or plant status switches.

IS Digital Outputs

Two Isolated Open-Collector Outputs are provided for access control or general purpose signalling.

Data from all the above options are available to the host computer via the communications ports, saving extra cabling and barriers.

Installation

The Mercury 2+ Terminal is designed for surface or pole mounting; its slim design and robust case allow considerable freedom of location.

The powder coated aluminium case and sealed polyester keyboard provide protection to IP65, allowing regular wash-down. The Mercury 2+ Terminal is resistant to a wide range of aggressive chemicals. An operating temperature range of -20°C to +60°C allows year-round outside use, even in harsh climates.

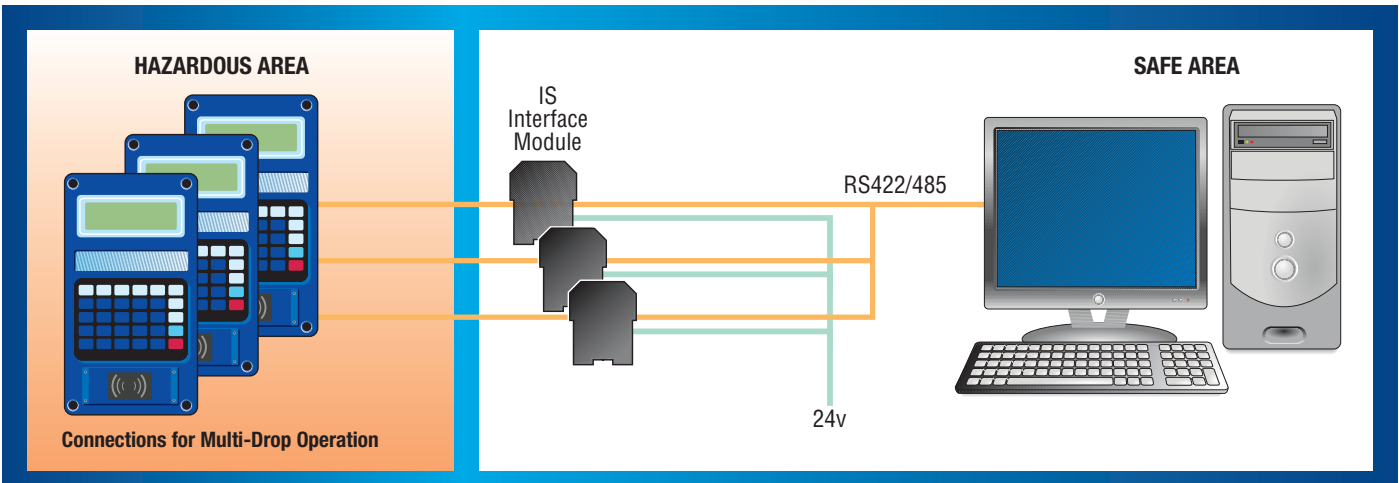
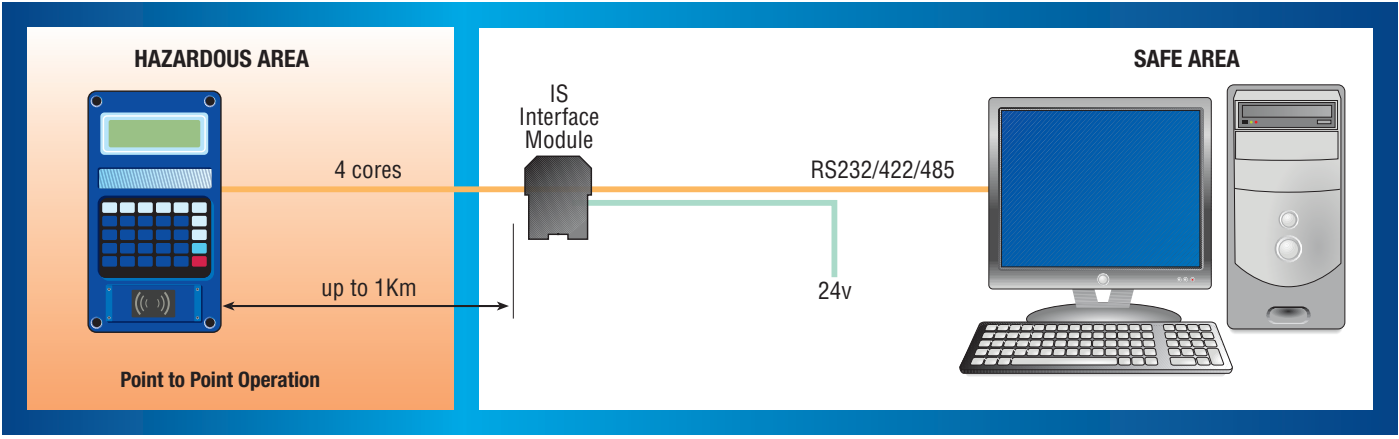
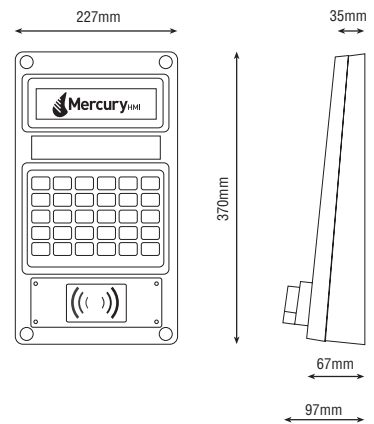

Specifications

MERCURY 2+

Certification:	ATEX EEx ia IIC T4 Ta = -20°C to +60°C, Zone 0, Certificate Number Sira 02ATEX2297X
Ambient temperature:	-20°C to +60°C (operating), -20°C to +70°C (storage)
Ingress protection:	IP65
Case:	Aluminium casting, powder coated, Weight: 5.5 Kg
Mercury 2+ Display:	Back lit Supertwist LCD, black characters on silver 40 x 8 characters (text mode) 240 x 64 pixels (graphics mode) Dual character size. Large = approx 12mm
Keyboard:	Polyester membrane type with 30 or 42 key matrix Upper case, lower case and numeric character sets Tactile and aural feedback 8 function keys
User memory:	7000 Bytes non volatile, up to 99 stored messages
Connections:	IS version, 4 wire connection to IS interface module Non-IS version, 2 wires power, 3 wire RS232 data or 2/4 wire RS485/422
Data protocol:	Based on VT100 or Modbus
Contact I/O:	3 off, internally-powered inputs for volt-free contacts. 2 off IS Digital Outputs, Isolated Open-Collectors

R507 IS INTERFACE MODULE

Hazard area connections:	Data/power to Mercury, 4 wires Galvanically Isolated, 20V, 100 Ohm
Cable Parameters:	4 cores or 2 twisted pairs, 1 km max 251 nF max 33 microH /Ohm max 20 Ohms per core max
IS earth:	Not required
Power:	20 - 32V dc, 2W nominal
Environment:	Safe Area
Ambient temperature:	-20°C to +60°C (operating) -20°C to +70°C (storage)
Humidity:	95%, non-condensing
Data connections:	RS232, RS422 or RS485
Mounting:	25mm rail to DIN 46277

IS PROXIMITY CARD READERS

The number of data bits and the data format from the proximity cards depends upon the card type in use. The Mercury 2+ terminal can be configured to pad or truncate the high or low data bits of the card data or reverse the data bits, for compatibility with other card systems.

Your Local distributor:

Further Information

Further information on the Mercury 2+ may be obtained from any of our Distributors and Sales Representatives, world-wide.

www.mercuryHMI.co.uk/contacts.html

- * Contact the factory for more information
- ** which ever comes first



Mercury HMI Limited
George House,
Derwent Road,
Malton, North Yorkshire.
YO17 6YB UK

Tel: +44(0)1653 697200
Fax: +44(0)8700 667325
Web: www.mercuryhmi.co.uk
Email: sales@mercuryhmi.co.uk