



Sentry

Sentry I.S. Card Reader User Manual

Instructions Specific to Hazardous Area Installations

The following instructions relevant to safe use in a hazardous area apply to equipment covered by certificate numbers Sira 99ATEX2138X.

1. The certification marking is as follows:-

Gas & Dust Variant



II 1 G
EEx ia IIC T4

II 2 D
Ex tb IIIC T85°C
Ta = -40°C to +60°C

Gas only Variant



II 1 G
EEx ia IIC T4

Ta = -40°C to +60°C

Dust only Variant



II 2 D
Ex tb IIIC T85°C

Ta = -40°C to +60°C

2. The equipment may be used in zones 0, 1 & 2 with flammable gases and vapours with apparatus groups IIA, IIB & IIC and with temperature classes T1, T2, T3, T4.
3. The equipment may be used in zones 21 & 22 with flammable dusts, fibres and flyings in groups IIIA, IIB and IIC, and temperature T85°C.
4. The equipment is only certified for use in ambient temperatures in the range -40°C to +60°C and should not be used outside this range.
5. Installation shall be carried out in accordance with the applicable code of practice by suitably-trained personnel.
6. There are no special checking or maintenance conditions other than a periodic check.
7. With regard to explosion safety, it is not necessary to check for correct operation.
8. The equipment contains no user-replaceable parts and is not intended to be repaired by the user. Repair of the equipment is to be carried out by the manufacturer, or their approved agents, in accordance with the applicable code of practice.
9. Repair of this equipment shall be carried out in accordance with the applicable code of practice
10. If the equipment is likely to come into contact with aggressive substances, e.g. acidic liquids or gases that may attack metals or solvents that may affect polymeric materials, then it is the responsibility of the user to take suitable precautions that prevent it from being adversely affected thus ensuring that the type of protection is not compromised.
11. The certificate number has an 'X' suffix which indicates that special conditions of installation and use apply. Those installing or inspecting this equipment must have access to the contents of the certificate or these instructions. The conditions listed in the certificate are reproduced below:-
 - (i) Glass Fibre Reinforced Plastic (GRP) enclosure and parts of the aluminum enclosure are non-conducting and may generate an ignition-capable level of static under certain extreme conditions. The user should ensure that the equipment is not installed in a location where it may be subjected to external conditions (such as high-pressure steam) which might cause a build-up of static on non-conducting surfaces. Additionally, cleaning of the equipment should be done only with a damp cloth.
 - (ii) As painted aluminium is used at the accessible surface of this equipment, in the event of rare incidents, ignition sources due to impact and friction sparks could occur. This shall be considered when the Sentry Cardreader is being installed in locations that specifically require group II, category 1G equipment.

Mercury HMI Ltd
George House
Derwent Road
Malton
North Yorkshire
YO17 6YB
UK

Tel: +44 (0) 1653 697 200
Fax: +44 (0) 8700 667 325
Email: sales@mercuryHMI.co.uk
Web: www.mercuryHMI.co.uk

All trademarks are acknowledged as the property of their respective owners.

This document shall not form part of any contract. Specifications are subject to change without notice, and Mercury HMI Ltd accepts no liability of any kind for errors or omissions.

Revision History

Rev	Date	Changes
1.0		Original Release
1.1		Mercury IMC Version
2.0	27 Jul 09	Substantial revision of the manual for Wiegand O/P Mode, R507 barrier and Modbus enhancements
2.1	6 Oct 09	All drawings re-drawn
2.2	2 Dec 10	The Digital Output driving page 17 has been revised. Table boundaries made finite thickness to help PDF printing Extra reader type added Config string updated Links show Mercury HMI Limited & logo. Certificate checked.
2.3	18 Mar 11	Added Special conditions of use
2014r0	11 Nov 14	Substantial revision of the manual Added GRP case information Added LED cable orientation Fixed Modbus coils
2015r0	1 Jul 15	Add Wiegand Output mode wiring diagram for Pepperl & Fuchs barriers
2016r0	29 Jul 16	Added Specific Conditions of use for Variation 5, including Dust to match Issue 7 of the Sira 99ATEX2138X certificate
2017r0	7 Mar 17	Minor updates

Introduction.....	6
System Overview.....	6
Power / Comms Options.....	6
Base Unit.....	6
Reader Types.....	7
Enclosure Material.....	7
Certification Standard.....	8
Installation.....	9
Overview.....	9
Mounting the Sentry Card Reader.....	10
Weatherproofing.....	10
Hazardous Area Connections.....	10
Twisted Pair Cabling.....	11
Safe Area Requirements.....	11
Safe Area Connections.....	12
Internal Overview.....	12
Operation.....	13
Power On.....	13
Set Up & Configuration.....	14
Configuring the Reader Card Type.....	14
Operating Mode.....	15
Configuration String.....	16
Example Configuration String.....	17
Telemetry Block Structure.....	18
Multi Drop.....	18
Data Only.....	18
Escape Sequences.....	19
Card Data	19
System Options.....	20
Option 1 : IS Sentry in Stand-alone mode.....	20
Option 2 : IS Sentry in Multi-Drop Mode.....	20
Option 3 : IS Sentry in Standard Modbus Mode.....	21
Option 4 : IS Sentry in Mercury 2+ Modbus Compatibility Mode.....	23
Option 5 : Safe Area Sentry.....	24
Option 6 : Wiegand D1/D0 Output Mode.....	25
Hazardous Area I/O.....	26
Appendix A - Wiring Diagrams.....	27
Appendix B - Specifications.....	34
Appendix C - Link Settings.....	35

System Overview

The Sentry Card Reader is a modular and highly configurable unit designed to read a variety of different card types in Hazardous Areas.

A complete Sentry Card Reader unit comprises of three main components, and there are several versions of each of these main components:-

- A power and communications safety barrier, or galvanic isolator, mounted in the Safe Area when the Sentry Card Reader is to be used in a Hazardous Area installation.
- The Sentry base unit, with the processing and communications electronics affixed in the Hazardous Area, connected to the fixed wiring.
- The Sentry lid, containing the appropriate reader head (the reader electronics and a safety barrier encapsulated together into a module mounted behind the RF transparent window) and the status LEDs.

Power / Comms Options

There are three power and communications types available:-

- For a Safe Area Sentry, the unit can be connected directly to a power source and the communications can be connected directly to a PC, PLC or DCS as needed.
- For a Hazardous Area Sentry, requiring serial communications within the Safe Area, then an R507 Interface Module is needed.
- If Wiegand D1/D0 communications is needed from a Hazardous Area mounted Sentry Card Reader, then a Safe Area mounted P510 Module together with a pair of standard zener barriers is needed. Mercury HMI recommend the use of MTL or Pepperl and Fuchs barriers, but other manufacturers can be accommodated.

Base Unit

There are then three variants of the Sentry base units:-

- Safe Area Serial Communication version. This requires a clean 24V power supply and provides RS422 or RS485 communications.
- Hazardous Area Serial communications version, supporting point to point, multi-drop and Modbus communications. An R507 Interface Module will be required in the Safe Area.
- Hazardous area Wiegand Output Version. A Wiegand Output kit comprising of a P510 Module and barriers is also needed.

Reader Types

The Sentry reader supports several different types of proximity card technology:-

- EM4001/4100
- MIFARE
- HID Prox (125kHz)
- AWID26/32
- HITAG
- SafeProx - this is a "secure" 125kHz card technology designed for use with the Mercury HMI products.

Support for new card types is on-going, so please contact Mercury HMI to enquire about any unlisted formats.

Note : the Sentry reader is only able to read the factory programmed serial number (UID) from proximity cards. For cards that allow user data to be stored on them (e.g. Mifare), the reader is not able to retrieve this user information.

Enclosure Material

The Sentry can be provided with either a powder coated, passivated aluminium housing, or a static dissipative GRP housing, perfect for marine and salty environments.

Note that the dust variants can only be supplied in the GRP housing.



Illustration 1 : Sentry Card Reader

Certification Standard

ATEX Number The SIRA certification No. 99ATEX2138X shows EEx ia IIC T4 for gas and Ex tb IIIC T85°C, which is made up as follows:-

EEx	=	European certificate for Hazardous Areas.
ia	=	Intrinsically Safe for Zone 0, continuous Hazardous vapours.
IIC	=	Safe for ALL gas groups.
T4	=	Component surface temperature cannot exceed 135°C.
Ex	=	Hazardous Area Product.
tb	=	Dust ignition protection by enclosure for Zones 21 and 22.
IIIC	=	Safe for ALL gas groups.
T85°C	=	Component surface temperature cannot exceed 85°C.

The "Conditions of Certification" show the maximum parameters of each of the input/output terminal blocks.

Nomenclature & Conventions

In this manual, ASCII single characters which are either control or non-visible codes (Hexadecimal 00_H - 1F_H, 20_H and 7F_H) are indicated by enclosure in <>, for example, <ESC>.

Character strings which are indivisible sequences are shown between quotation marks, for example, "<ESC> [2 J".

In the ASCII 7 and 8 bit code sets used by the Sentry Card Reader, a character is represented by two digits, each in the range hexadecimal 0 to F. For example, <SP>, the space character is defined 20_H.

Installation Overview

The Sentry Card Reader has ATEX approval for use in Hazardous Areas when used with the R507 Interface Module or a direct equivalent.

The Intrinsically Safe Interface Module provides galvanic isolation between the 24V D.C. power & host communication ports and the I.S. Hazardous Area connection.

These connections to the Sentry allow a cable length of up to 1km (when used with an R507) or 500m (when in Wiegand D1/D0 mode). The R507 communication ports provide for RS232 and differential transmit and receive terminals for RS422/485, with tri-state control.

The Sentry should be ordered as a complete unit comprising base unit and appropriate lid as required. The Sentry can then be mounted on any convenient flat surface using the four holes provided.

The dimensions of the box are shown in the diagram below.

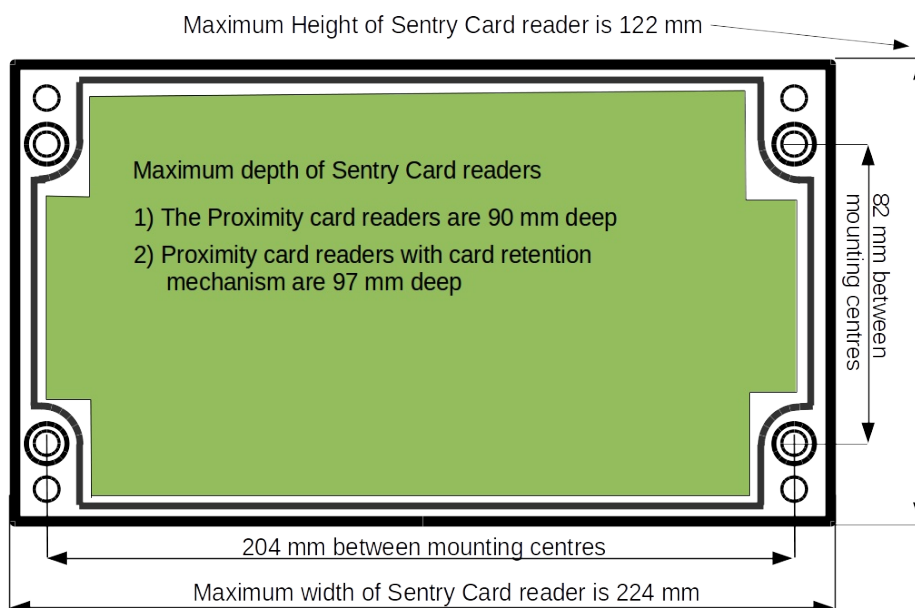

Illustration 2 : Sentry Mounting Hole Centres

Mounting the Sentry

To affix the Sentry Card Reader to a surface, prepare by drilling four holes 204 mm apart in width and 82 mm apart in height, refer to Illustration 2. Carefully remove the Sentry Lid containing the reader head and LEDs, supporting the lid so that the cables are not put under strain. If this is not possible, carefully remove reader head plug from J2 (see Illustration 4) and the LED assembly plug from J1 and store the reader head safely.

Four mounting screws can now be used to attach the Sentry Base Unit to the mounting surface.

Now plan how the hazardous area wiring is going to be terminated. For a simple IS installation, when the only connections are the 4 wires to the Sentry, use the left hand gland.

Weatherproofing

The Sentry Card Reader is weatherproof, but care must be taken to ensure the “O” ring seals are in place and free from grit when mounting the equipment.

In salty or corrosive areas, it is advisable to grease the lid screws to avoid binding. Alternatively, the GRP enclosure may be a better choice as it offers better protection, especially in marine environments.

There are three 20mm threaded holes provided in the box for cable glands. Two gland holes are provided with blanking plugs, the other gland must be provided by the customer.

In its most basic configuration, Sentry wired to host, only one cable is needed (See Appendix A drawing number P174'112 and P174'113).

Hazardous Area Connections

For hazardous area applications, the cable connecting the R507 power and communications interface needs to comply with the following parameters:

Loop Resistance	40 Ω Maximum
Capacitance	142 nF Maximum
L/R Ratio	33 $\mu\text{H}/\Omega$ Maximum
Inductance	0.6 mH Maximum

In practice these parameters are easily met by standard cables;

e.g. a 1 mm² quad cable has approximately the following parameters:-

Loop Resistance	38 Ω/km Maximum
Capacitance	55 nF/km Maximum
L/R Ratio	2.5 $\mu\text{H}/\Omega$ Maximum
Inductance	0.48 H/km Maximum

For a cable length of 1km, this would satisfy safety and operating requirements.

Twisted Pair Cabling

If twisted pair cabling is used, one twisted pair should be used for the TX+ wires, and the other twisted pair should be used for the RX- wires, as follows:-

Twisted Pair	Sentry J5	R507
Transmit pins	1 (A+)	15 (Tx2+)
	2 (B+)	16 (Tx1+)
Receive pins	3 (A-)	13 (Rx2-)
	4 (B-)	14 (Rx1-)

Note: If TX+ and RX- wires are used in the same twisted pair, this may result in communications problems and data corruption.

Safe Area Requirements

For hazardous area use, the Sentry must be connected to the R507 power and communications interface. The R507 must be located in the Safe Area.

An illustration of the interface module, which is designed to be mounted on a DIN rail, is shown below:-

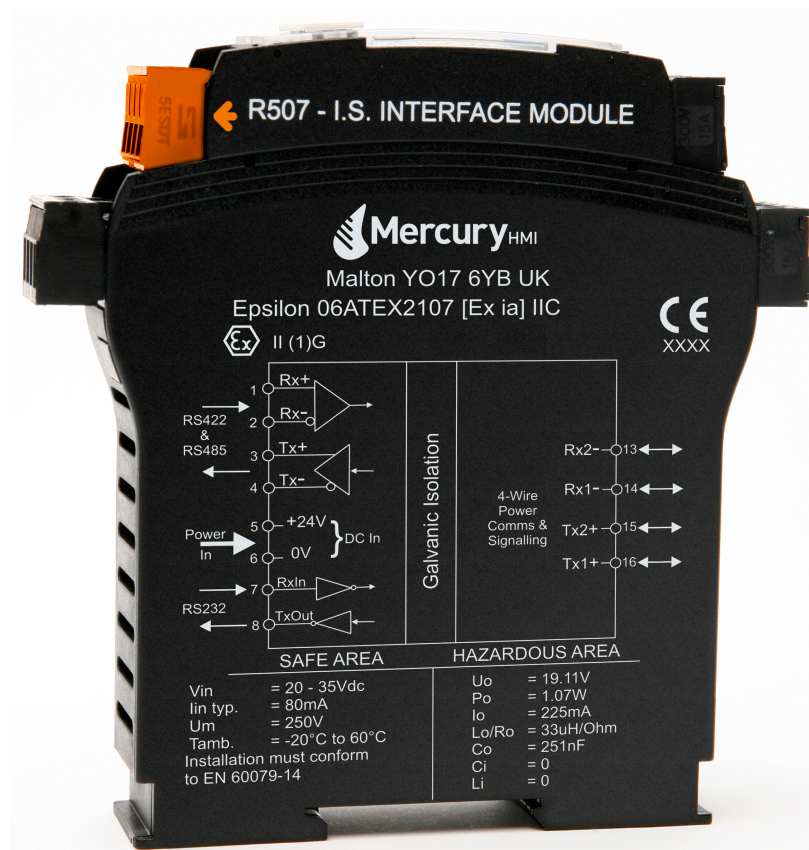

Illustration 3 : R507 IS Power and Comms Isolator

Safe Area Connections

For Safe Area use, the hazardous area parameters are not applicable and any suitable communications cable can be used.

In a Safe Area application, the host can be connected directly to the Sentry card reader RS422 connections as shown in Appendix A.

The wiring terminals are screw terminals on a 5.08 mm pitch; each capable of accepting 2mm diameter cores or ferrules.

For connection details of power and signals, see the wiring diagrams in Appendix A.

Internal Overview

Illustration 4 shows an overview of the key internal components and connections.

It should be noted that, due to space limitations, the connector used for J1 does not use a 'keyed' plug. As such, it is possible to connect the socket the wrong way round.

The correct orientation is with the small plastic lugs pointing away from R1 ... R3 and towards the closest edge, as follows:-

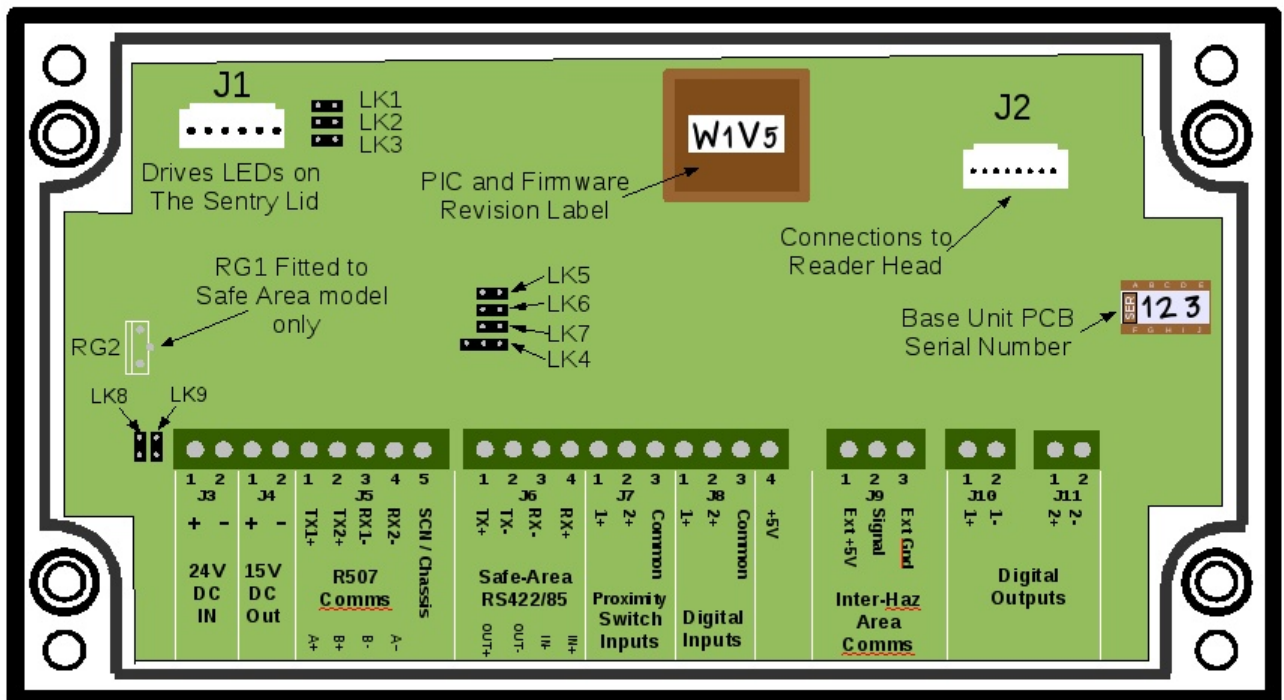
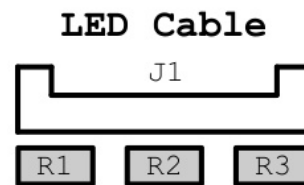

Illustration 4 : Inside view of the Sentry, showing key components and connections

Power On Assuming the device is correctly wired, when the 24V power is applied to the R507 power and communications interface, the Power/Comms LED Indicator (the uppermost one) will alternate between RED and GREEN whilst the other indicators will flash RED.

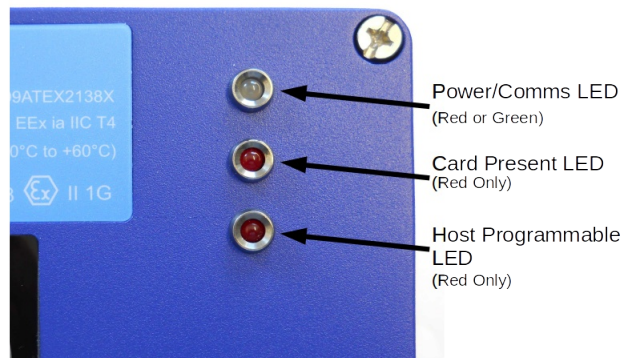

Illustration 5 : Showing the LED indicators

Once the unit has performed its start-up tests, the Power/Comms LED Indicator is illuminated Green to show the unit is powered and ready for operation.

When a proximity card is within the RF field, the Card Present LED will be illuminated.

Once the card has been successfully read, the data from the card is decoded, and then sent back to the Safe Area where it is available from the barrier and communications interface in Serial RS232/422/485 format as ASCII characters.

The Power/Comms LED Indicator briefly changes colour (from GREEN to RED) to indicate the card data has been successfully decoded and transmitted.

The Host Programmable LED can be set to be On, Off or Flash, utilising commands sent using the serial communications channel by the host to which the Sentry Card Reader is connected.

Note: although this LED is fitted to all models, it cannot be controlled in Wiegand output mode.

Set Up & Configuration

With the equipment suitably connected, the Sentry can then be configured for use.

The factory default settings are:-

Baud Rate:	9600
Word Length:	8
Stop Bits:	1
Parity:	None
Telemetry Mode:	Point-to-Point
Output Structure:	Data Only
Start/stop bit operation:	
Wiegand cards	Start = 1, stop = 0
Proximity cards	Include parity bits

To change the default set up, the links LK5 and LK6 in the Sentry unit should be changed accordingly and then the new set up downloaded to the Sentry.

The link configurations are shown in section **Operating Mode**.

Configuring the Reader Card Type

For correct operation jumper links LK2 and LK3 on the card reader main board must be set to correspond with the type of card reader head fitted as follows:-

Card Reader Type	LK3	LK2
Proximity	Off	Off
Reserved	Off	On
Reserved	On	Off
Reserved	On	On

NOTE: The Card Reader Type link settings will be correct when the unit is received from the factory and only needs changing if the lid is changed for a different card technology.

The board must be restarted for these settings to take effect.

Operating Mode

The card reader has various modes of operation. This is determined by the position of bit links LK6 and LK5 at start-up:-

Operating Mode	LK6	LK5
Run as Configured	Off	Off
Reserved (for future use)	Off	On
Load New Configuration	On	Off
Run as Default Configuration	On	On

Illustration 4 shows the locations of the links on the main Sentry PCB together with their functions.

The “Run as Configured” mode configures the Sentry Card Reader using the last stored user configuration.

The "Run as Default Configuration" mode over-rides any user configuration, and hence gives a known setup to allow communications to be established.

The “Load New Configuration” mode also starts the card reader with the default settings loaded, but in addition it allows new configuration data to be uploaded to the card reader for storage in non-volatile memory. This user defined new configuration data is then only used when the card reader is restarted with bit links set for “Run as Configured” mode.

A configuration string is uploaded to the card reader via the communications port using any ASCII terminal. This is initiated by the keyword “config” followed by the configuration data itself. The configuration string must be terminated by the “@” character to invoke a transfer from the input buffer to non-volatile memory.

Mercury HMI Ltd also provide a simple Windows program that can be used to configure the Sentry. Please contact Mercury HMI for more details or visit <http://www.mercuryhmi.co.uk/downloads>.

Configuration String

The configuration string uses the following format:

```
config<baud rate>,<parity>,<word length>,<stop bits>; <telemetry mode>[,<telemetry address>];<output structure>;<multi-drop acknowledge>;<start/stop bit operation>;<reverse data>;<data byte count>@
```

Available options are shown in the table below (**bold** values denote the default setting):-

Parameter	Option
Baud Rate	1200, 2400, 4800, 9600 , 19200
Parity	None , Odd, Even, Mark, Space (sent as n , o, e, m, s)
Word Length	7, 8
Stop Bits	1 , 2
Telemetry Mode	Point-to-Point (sent as pp) Mercury Multi-drop (sent as md) Modbus (sent as mb) Mercury 2+ Modbus (sent as m2)
Telemetry Address	1 to 64 Note : omit this if configuring as Point-to-Point mode
Output Structure	0 (Data Only) , 1 (Mercury Multi-drop Format) 2 (Data + <ETX>)
Multi-drop Acknowledge	Disabled (sent as 0) Enabled (sent as 1)
Multi-mode Start / stop bit operation	In Proximity mode:- Include start / stop parity bits (sent a 0) Strip start / stop parity bits (sent as 1) In Wiegand mode, this detects:- Start bit = 1, stop bit = 0 (sent as 0) Start bit and stop bit opposite polarity (sent as 1)
Reverse data	Disabled (sent as 0) Enabled (sent as 1)
Data byte count	2 byte value denoting the number of data bytes to be output. The data is padded or truncated as required. If the default value ' 00 ' is used, the original card data is output.

Example Configuration String

config9600,n,8,1;md,12;0;1;1;0;00@

After loading this string into non-volatile memory the card reader immediately reads it back and transmits it to the host terminal (with the Sentry base unit PCB serial number appended) to confirm success of the write. For example, the user would see:-

```
config9600,n,8,1;md,12;0;1;1;0;00
Serial #:00000123
```

Once the string is uploaded, the user should:-

1. Power off the card reader for 5 seconds.
2. Change the links to 'Run as Configured' mode.
3. Power on the card reader.

Alternatively, for Windows users, there is a simple test and configuration package available for free download from the Mercury HMI website (<http://www.mercuryhmi.co.uk/downloads>).

The picture below shows the view of the configuration tab.

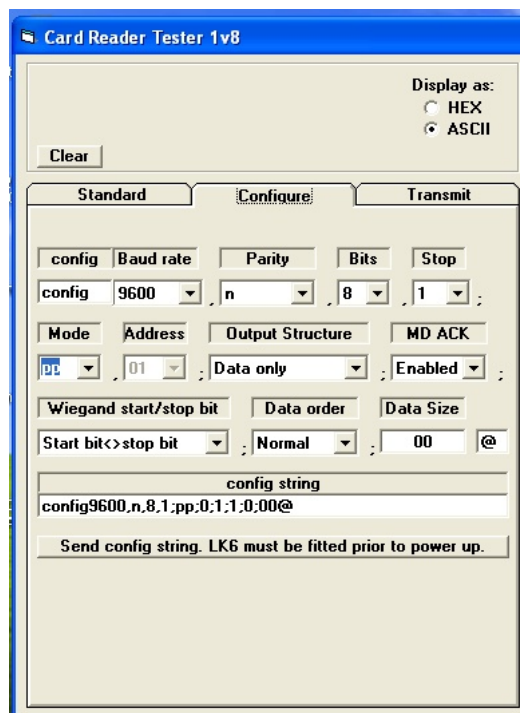

Telemetry Block Structure

Multi Drop

When Mercury Multi-drop output format is selected, messages between the Card Reader and host follow the format:-

"<STX> ADDR FUNC ID DATA DMY CSUM <ETX>"

<STX> is the Start Transmission character (02_H)

ADDR is a two-byte address field. Each byte is the ASCII equivalent of a number 0 to 9. This number is not relevant except in multi-drop mode. It is the Telemetry Address and can take the value 01 to 64.

FUNC is a single byte character used to determine the type of information being sent. It is always "D" (44_H) when transmitted from the card reader, and "R" (52_H) when transmitted to the card reader.

ID is the identification of the source of the block. It is a single byte used to distinguish between the various sources of block data. Possible values are:-

'E' (45 _H)	Digital Input
'G' (43 _H)	Proximity Card
'P' (50 _H)	Card Present
'V' (56 _H)	Software Version

DATA is the field used to send information.

DMY is a single character whose value is chosen to ensure that the following CSUM byte is not a control character. The value of DMY is usually 00_H but if this would result in the CSUM being a control character, the DMY would be set to 20_H

CSUM is a single byte checksum character. This is the 7 bit negated algebraic sum of all the characters in the string from the STX up to and including the DMY byte.

<ETX> is the End Transmission character (03_H).

Data Only

If "data only" is selected as the output structure, only the hex-ASCII data is output, with no header or trailer characters.

Escape Sequences

The Card Reader responds to the following escape sequences, which are a subset of those used by a Mercury Terminal:-

Send Next Queued Block: “<ESC>[?9;1z”
(Multi-drop mode only)

Re-Send Last Queued Block: “<ESC>[?9;2z”
(Multi-drop mode only)

Enable Card Reader in One Shot Mode “<ESC>[?15;4z”
Disable Card Reader: “<ESC>[?15;5z”
Enable Card Reader: “<ESC>[?15;6z”

Note: these commands enable / disable the device regardless of the card media type it is configured to read.

Sample Dig Ins: “<ESC>[?4z”

Set Dig Outs: “<ESC>[?5;nz”

where **n** is one of the following:-

n	Dig Out #1	Dig Out #2
0	On	On
1	Off	On
2	On	Off
3	Off	Off

Read Config: “<ESC>[?2z”
which returns the configuration data string and serial number.

Set Host LED: “<ESC>[?6;1z”

Clear Host LED: “<ESC>[?6;2z”

Flash Host LED: “<ESC>[?6;3z”

Read Software Version “<ESC>[?6;0z”

There are a number of different ways the Sentry Card Reader can be used depending upon the requirements of the particular system.

The following information describes some of these system options regardless of the type of card reader used as this is incidental to the system involved.

Option 1 IS Sentry in Stand-alone Comms mode

To operate in this mode, the Telemetry Mode in the configuration string has been set to "pp" or the Sentry is running in it's default mode.

This is a very straightforward system option. The Sentry is connected by a four-core cable directly to the R507 in the safe area.

This is in turn supplied with a 24V DC supply and the information is communicated to the host via RS232/422 or RS485 depending upon the requirements.

The Safe Area host device can be any device capable of communicating using VT100 (serial ASCII) protocol and electrically compatible with any of the three communications standards available at the R507.

Drawings No. P174'112 and P174'113 shows the necessary connections in this configuration (see Appendix A).

Option 2 IS Sentry in Multi-Drop Comms Mode

To operate in this mode, the Telemetry Mode in the configuration string has been set to "md".

This operation is basically an extension of the stand-alone mode, and would typically be used where a number of Sentry units are required to interface to a single port on the host device.

Up to 64 Sentry units can be connected in this way and they will respond only when a message is sent to the correct address.

It is important to note that the "daisy chain" wiring for the Multi-drop connection is carried out in the safe area. This is because the four wires in the hazardous area carry both power and communications and it is therefore impossible within the constraints of Intrinsically Safe equipment design to carry sufficient power from one safe area connection to power a number of Sentry units.

Drawing No. P174'113 shows the necessary connections in this configuration for a full duplex host connection allowing two way data flow simultaneously (see Appendix A).

Option 3 IS Sentry in Standard Modbus Mode

To operate in this mode, the Telemetry Mode in the configuration string has been set to "mb".

This operation is similar to the multi-drop mode, in so much as it can be used where a number of Sentry units are required to interface to a single port on the host device, and the units are wired in exactly the same manner, only the configuration string used to set up the Sentry would be different.

Below is a table of Modbus registers / coils and their associated function:-

Type	Short Address	"Long" Address	Function Codes	Command
Read Holding Register	0	40001	FC03	Read Software Version
	1	40002	FC03	Read Digital Inputs
	2 - 17	40003 - 40018	FC03	Read Card Reading
Read Input Register	0	50001	FC04	Read Software Version
	1	50002	FC04	Read Digital Inputs
	2 - 17	50003 - 50018	FC04	Read Card Reading
Force Output Coil	0	60001	FC05	Enable User LED
	1	60002	FC05	Disable User LED
	2	60003	FC05	Flash User LED
	3	60004	FC05	Enable 1-Shot mode
	4	60005	FC05	Disable Card Reader
	5	60006	FC05	Enable Card Reader
	6	60007	FC05	Clear Card Reading
Write Output Register	0	70001	FC06	Set Digital Outputs
	1	70002	FC06	Set Command Register

Read Input Register 1 using FC03 (or FC04), i.e. Read Digital Inputs, the bit pattern is:-

Bit	Function
0	Proximity Switch Input 1
1	Proximity Switch Input 2
2	Digital Input 1
3	Digital Input 2
4	Reserved (read as a 0 in current firmware)
5	Reserved (read as a 0 in current firmware)
6	Card Present Bit
7-15	Reserved (read as a 0 in current firmware)

Write Output Register 1 using FC06 will Set Command Register. The Command Register bit pattern is:-

Bit	Operation
0	Enable User LED
1	Disable User LED
2	Flash User LED
3	Enable One-Shot Mode
4	Disable Card Reader
5	Enable Card Reader
6	Clear Card Reading
7-15	Ignored

Note for Bits 0,1 & 2 as well as bits 3, 4 & 5, only one bit should be set at a time. If more than one bit is set, the highest bit takes precedence.

Bits	Operation
2 1 0	
0 0 1	Enable User LED
0 1 x	Disable User LED
1 x x	Flash User LED

Bits	Operation
5 4 3	
0 0 1	Enable One-Shot Mode
0 1 x	Disable Card Reader
1 x x	Enable Card Reader

Once a card has been scanned, it will remain in the “Card Reading” buffer until it is cleared using Output Coil 6 (Clear Card Reading).

If the user attempts to scan another card before the current reading has been cleared, the existing card data is retained and the new card data is ignored. To indicate this situation, the Power/Comms LED will flash 5 times.

When no card has been scanned, the “Card Reading” buffer will contain all zeros.

Example Modbus Comms

As an example, to read the Digital Inputs and Card Data, from a Sentry, that has been set with a Modbus Slave Address of 17, you would send:-

ADDR	FUNC	Start Reg Hi	Start Reg Lo	Count Hi	Count Lo	Check Field
11	03	00	01	00	03	CRC

The response you would get would be:-

ADDR	FUNC	Byte Count	Reg Hi	Reg Lo	Reg Hi	Reg Lo	Reg Hi	Reg Lo	Check Field
11	03	06	40002	40002	40003	40003	40004	40004	CRC
			00	"DI"	A	B	C	D	

The Card Data is read as DCBA.

For example, if A = 55 Hex, B = 20 Hex, C = 01 Hex and D = 00 Hex, then the card data in hex would be 00012055 (Hex) or 73813 (Decimal).

Modbus Data Reading Sequence

If the host polls the Sentry when no card has been presented, the card data holding registers will each contain 0000.

If the host polls after a card has been presented, read by the Sentry and kept in the vicinity of the Sentry, the holding registers will now contain the card data and the Digital Input Register will have Bit 6 active.

If the host continues to poll but move the card away from the Active zone of the Sentry, the holding registers will still show the data from the last card read, but the Digital Input Register will have Bit 6 cleared. You will have to issue a Clear Card Command to reset the card data to all zeros.

Alternatively, if the host issues the Clear Card Command but leaves the Card in the active zone of the Sentry and then poll the Sentry, the host will see in the response that the holding registers will now contain all zeros for the card data and the Digital Input Register will have Bit 6 active.

Option 4 IS Sentry in Mercury 2+ Modbus Compatibility Mode

To operate in this mode, the Telemetry Mode in the configuration string has been set to "m2".

This operation is very similar to the standard Modbus mode, but an alternative mapping is available, to make integration with Mercury 2+ units simpler. The mapping of the bits within the registers is the same as standard Modbus mode, only the register addresses have changed.

Below is a table of Mercury 2+ Modbus registers / coils and their associated function:-

Type	Short Address	"Long" Address	Function Codes	Command
Read Inputs Coils	0	30001	FC02	Read Proximity Switch Input 1
	1	30002	FC02	Read Proximity Switch Input 2
	2	30003	FC02	Read Digital Input 1
	3	30004	FC02	Read Digital Input 2
	4	30005	FC02	Reserved (read as 0)
	5	30006	FC02	Reserved (read as 0)
	6	30007	FC02	Read Card Present Bit
	7	30008	FC02	Reserved (read as 0)
Read Input Register	0	50001	FC04	Read Data Pending (Bit 15 = Card Present)
	1	50002	FC04	Reserved (read as 0)
	2 - 17	50003 - 50018	FC04	Card Data (ASCII)
	18 - 19	50019 - 50020	FC04	Card Data (Binary)
	35	50036	FC04	Read Software Version
Force Output Coil	107	60108	FC05	Clear Card Data Input Buffers
	111	60112	FC05	Enable User LED
	112	60113	FC05	Disable User LED
	113	60114	FC05	Flash User LED
Write Output Register	4	70005	FC06	Set Card Reader Mode 1 = One-Shot 2 = Disable 3 = Enable
	5	70006	FC06	Set Digital Outputs 0 = Dig Out #1 On 1 = Dig Out #1 Off 2 = Dig Out #2 On 3 = Dig Out #2 Off

Option 5 Safe Area Sentry

Although designed to be used in hazardous areas, the Sentry is equally suitable for non-hazardous area use.

The combination of a robust design, long distance communications, digital inputs, proximity detectors and digital outputs make its use sensible for other harsh rather than hazardous area uses.

In this case many of the constraints imposed by hazardous area equipment legislation can be disregarded, making system connection altogether simpler.

Drawing number P174'116 shows the system connection for this configuration (see Appendix A).

The major difference is that devices can be connected direct to the Sentry's RS485/422 terminals rather than through a barrier of any kind.

Similarly, input/output devices can be connected directly to the Sentry as long as the power requirements can be met, without recourse to either flame-proof boxes and safety characteristics.

The only other requirement for the safe area Sentry is a power supply of 24V at 100mA.

Option 6 Wiegand D1/D0 Output Mode

The Sentry can be ordered from the factory with different firmware that provides a Wiegand output mode, specifically designed for when a hazardous area card reader is required to interface with a traditional security and access control system.

The operation of the Sentry in Wiegand D1/D0 Output mode is entirely different from any of the serial communications mode detailed above.

For example, neither the User LED nor the Digital Outputs can be accessed, since there is no way to send information to the Sentry and neither the card proximity information, the Digital Inputs nor the Proximity Switch Inputs can be used, as there is no method of transmitting this info from the Sentry.

The Wiegand D0/D1 data is regenerated and driven out of the Sentry Digital Outputs. This information can then be sent to the safe area using a standard switch barrier. As serial communications are not required, a standard power barrier can be used to power the Sentry in the hazardous area.

Drawing number P174'115 shows the system connection for this configuration (see Appendix A).

Option 6 Configuration

There are 3 parameters that can be changed in Wiegand D1/D0 mode. These are pulse speed, parity bits recalculation and 32bit data limit.

Appendix C shows the relevant link settings for these options.

Sentry Expansion Connections

The Sentry has been designed with system solutions in mind and as such has input/output capability to interface with other equipment.

However, it is important to note that any equipment connected to the Sentry in the hazardous area must not infringe the rules governing equipment for such areas.

For example, the Sentry digital inputs must only be connected to equipment that complies with the safety description for the inputs.

Two Intrinsically Safe NAMUR proximity sensors can be connected directly to the Sentry Card Reader, using terminals 1 to 3 on terminal block J7. Refer to page 2 of the SIRA ATEX Certificate to find the hazardous area terminal characteristics. Note that J7 is described (from a safety perspective) as a Proximity Switch Output, since our circuitry puts a very small, tightly controlled amount of energy out, to operate the sensor.

In addition two whetted Digital Inputs are provided on J8 terminals 1 to 3, to allow direct connection to simple equipment such as a microswitch.

Two opto-isolated digital outputs are provided on J10 and J11 which can be used to control annunciators or indicators for example in the hazardous area.

Wiring Drawings

- P174'112 I.S. Sentry using R507 with RS232 Communications
- P174'113 I.S. Sentry using R507 with RS422 Communications
- P174'114 I.S. Sentry Peripheral Wiring
- P174'116 Safe Area Sentry RS422 Communications
- P174'117 I.S. Sentry using Wiegand Output Comms with P&F Barriers (for Security Systems)
- P174'119 Sentry using RS485 Communications

Sentry Card Reader

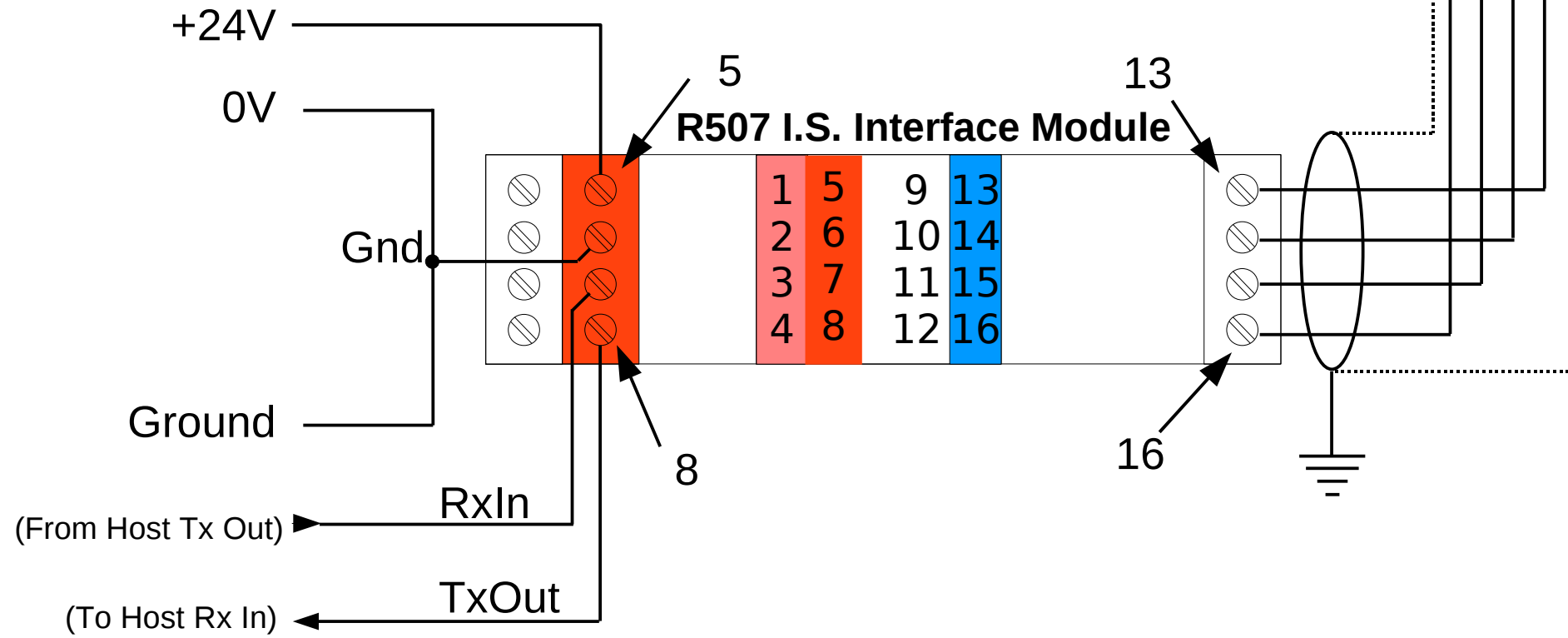
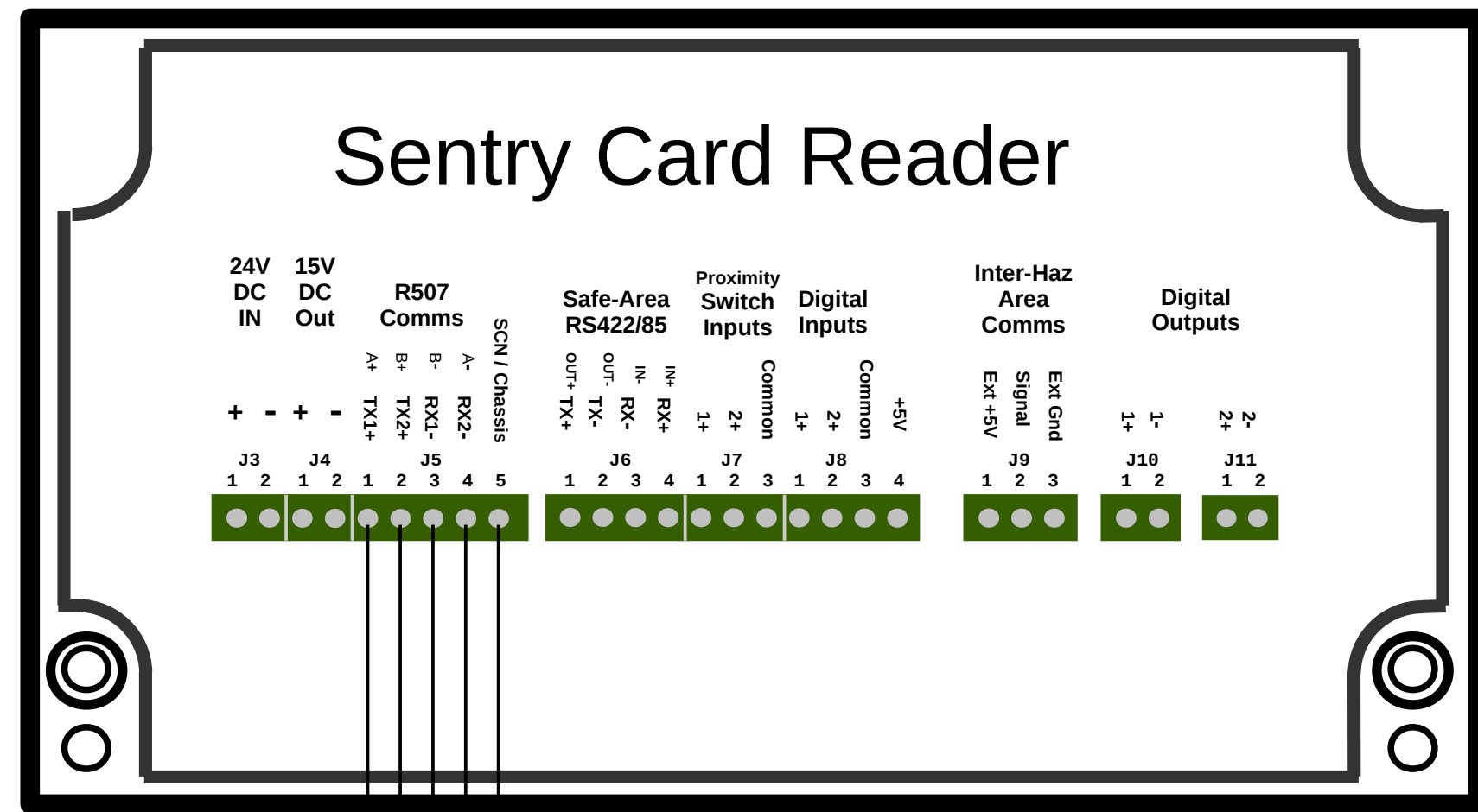

Related Product Document
The QAN Responsible Person must Approve any Changes or ECNs

This drawing may not be reproduced without the consent of Mercury IMC Ltd
© Mercury IMC Ltd, 2008



4					
3					
2					
1					
0	14Sep09	MOB	MSC	MPFJ	Initial Drawing
Revision	Date	Drawn	Chk'd	App'd	Description

Sentry Card Reader

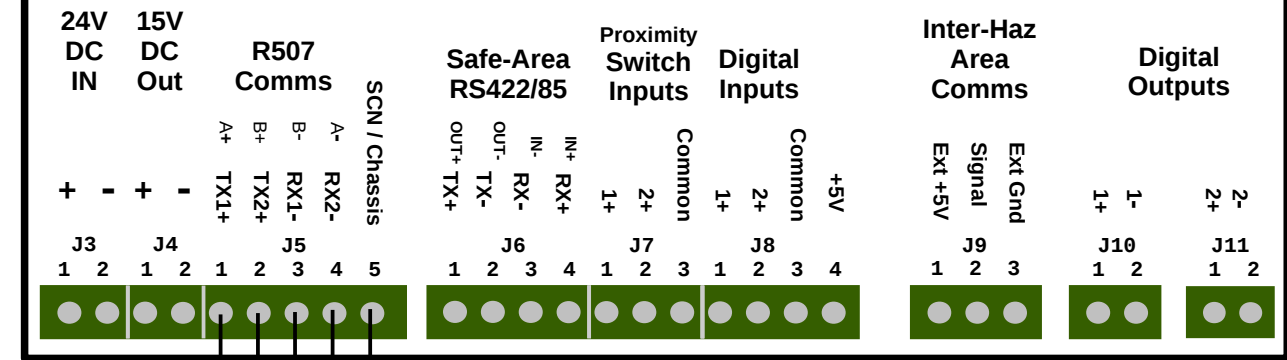

Sentry Card Reader

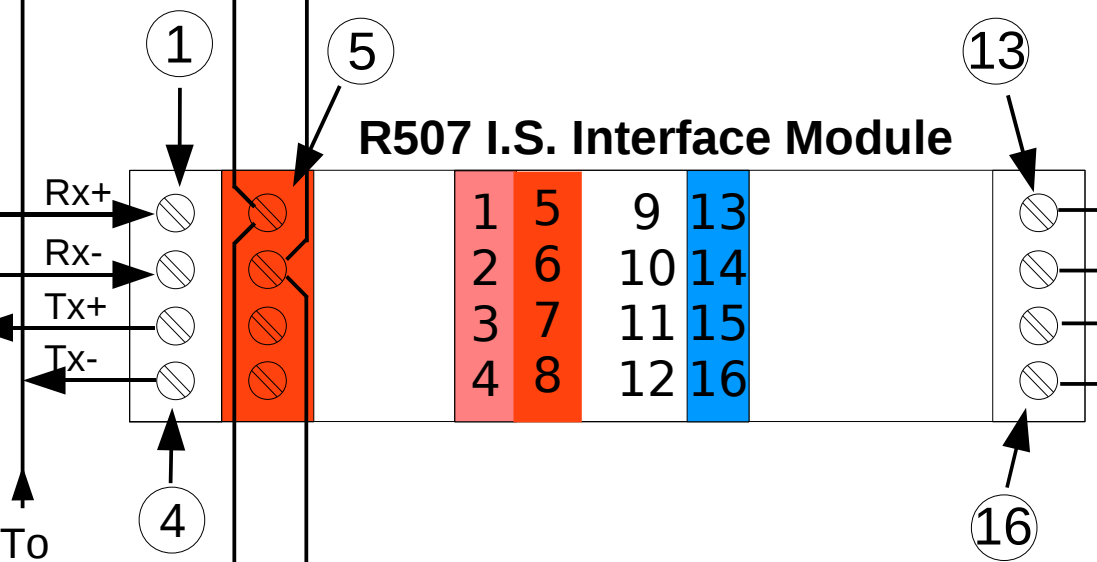
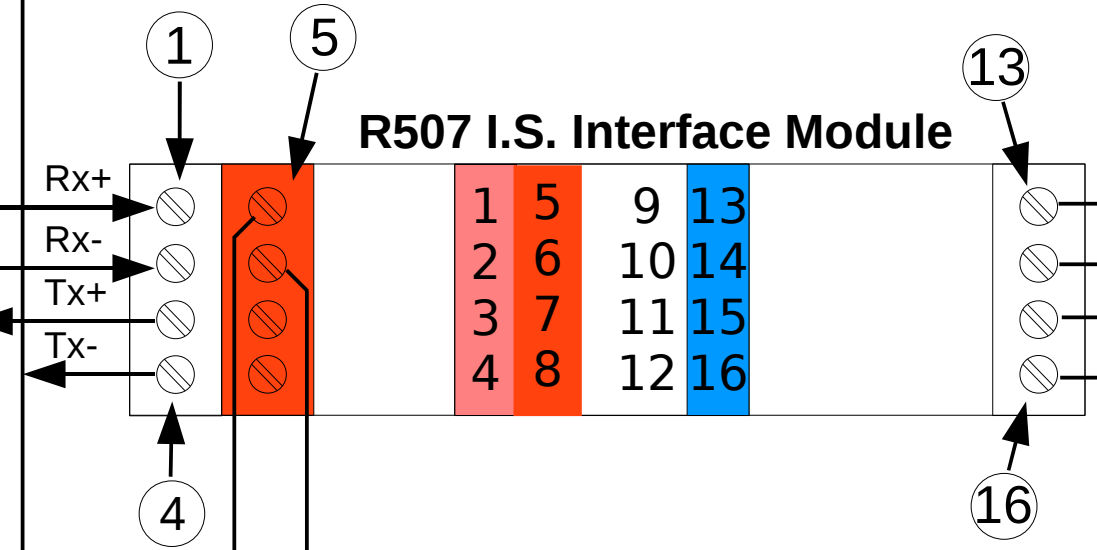
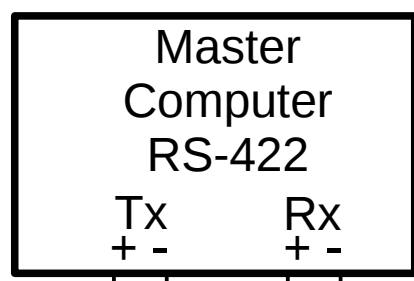
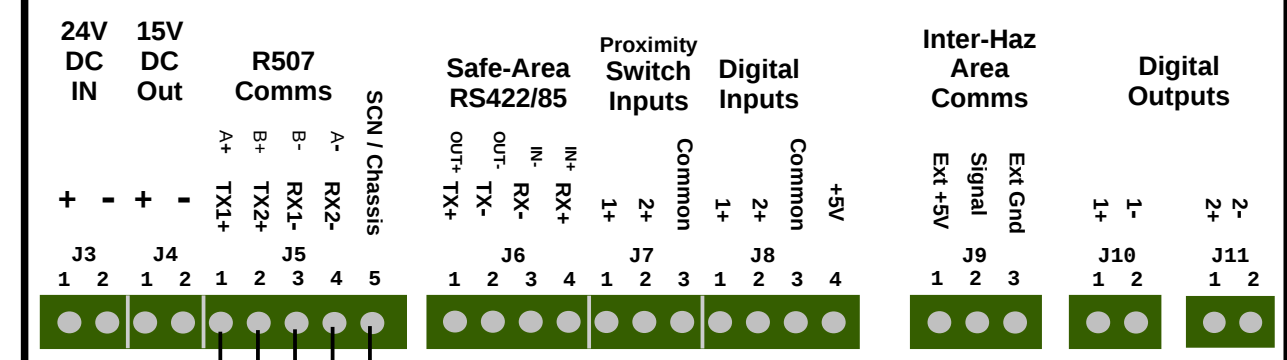

RS-422 Bus To Other Devices

24V +
-

Related Product Document
The QAN Responsible Person must Approve any Changes or ECNs

This drawing may not be reproduced without the consent of Mercury IMC Ltd
© Mercury IMC Ltd, 2008



4					
3					
2					
1					
0	14Sep09	MOB	MSC	MPFJ	Initial Drawing
Revision	Date	Drawn	Chk'd	App'd	Description

Title: Wiring Diagram – IS Sentry using RS-422

Sentry Card Reader

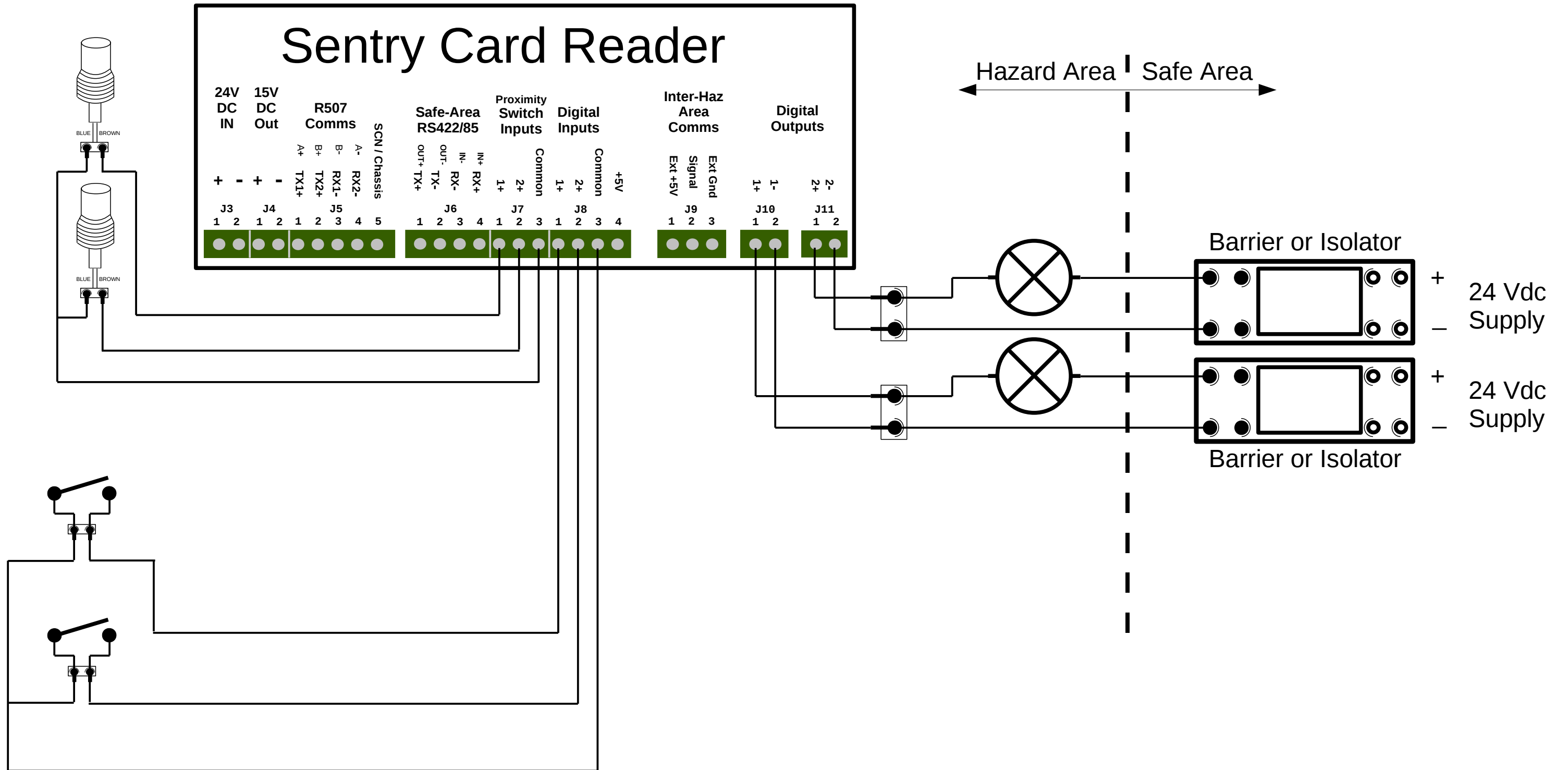

Related Product Document
The QAN Responsible Person
must Approve any Changes or ECNs

This drawing may not be reproduced without the consent of Mercury IMC Ltd
© Mercury IMC Ltd, 2008



Revision	Date	Drawn	Chk'd	App'd	Description
4					
3					
2					
1					
0	14Sep09	MOB	MSC	MPFJ	Initial Drawing

Safe Area Sentry P/N 8180281C "X"

Sentry Card Reader

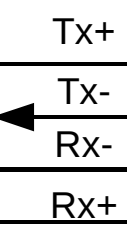
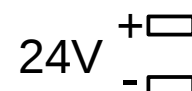
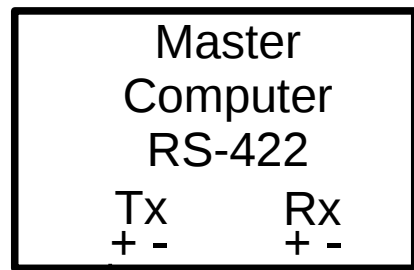
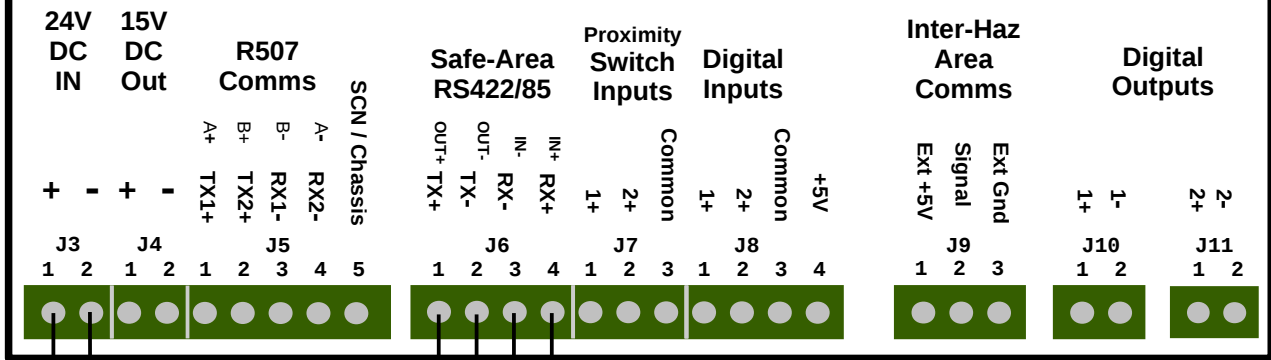

Safe Area

Hazardous Area

Hazardous Area

Sentry Card Reader

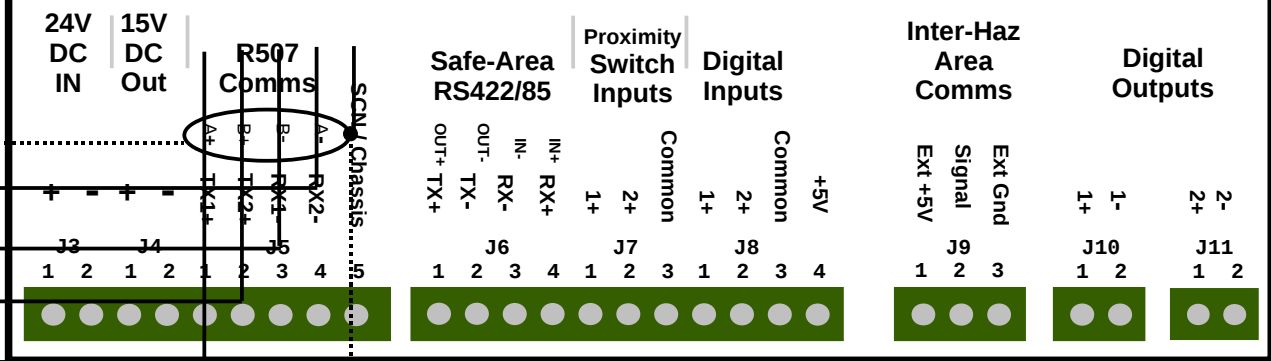

R507 I.S. Interface Module

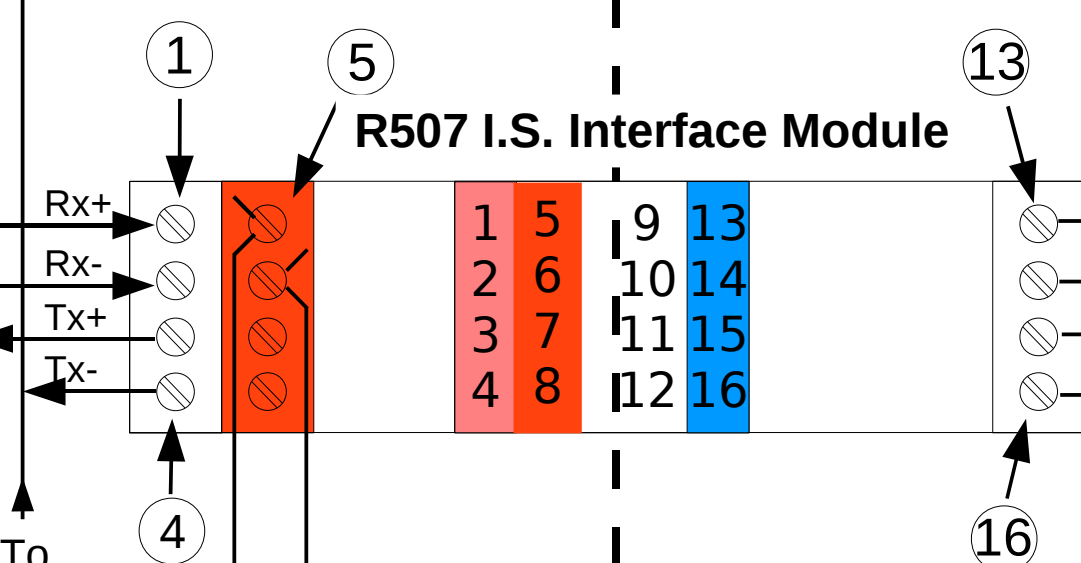

RS-422 Bus To Other Devices

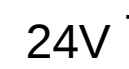

Related Product Document
The QAN Responsible Person must Approve any Changes or ECNs

This drawing may not be reproduced without the consent of Mercury IMC Ltd
© Mercury IMC Ltd, 2008



4					
3					
2					
1					
0	14Sep09	MOB	MSC	MPFJ	Initial Drawing
Revision	Date	Drawn	Chk'd	App'd	Description

Sentry Card Reader Wiegand Output Version

P+F "Barriers"

Comms Isolator KFD2-SOT2-Ex2 Bit Switch Settings

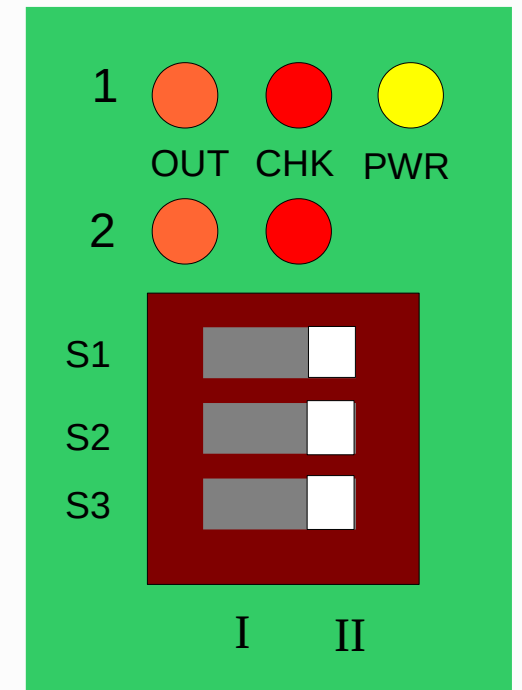

Ensure ALL bit-switches
Are set to the position II

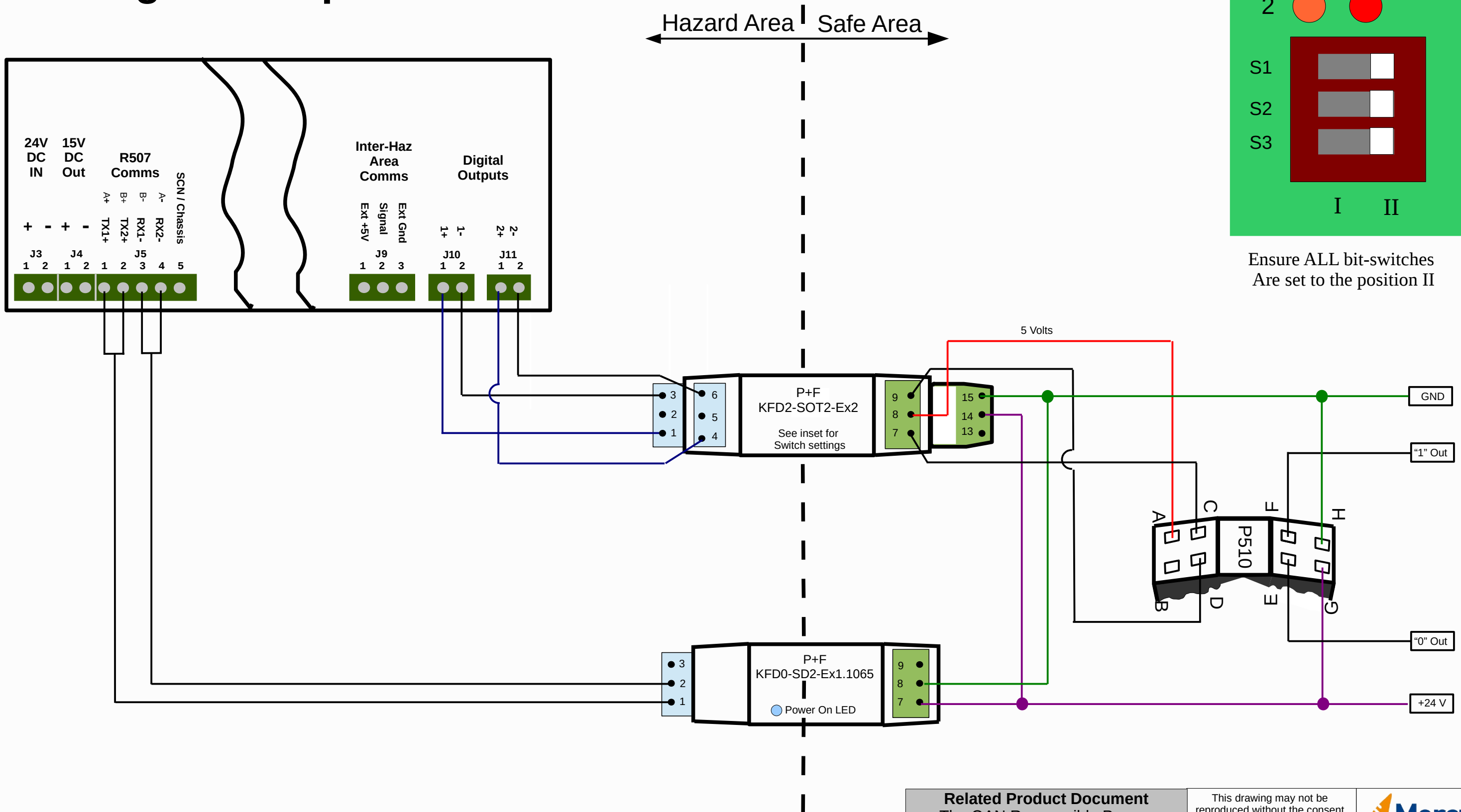

Related Product Document
The QAN Responsible Person
must Approve any Changes or ECNs

This drawing may not be
reproduced without the consent
of Mercury HMI Ltd
© Mercury HMI Ltd, 2013



4					
3					
2					
1					
0	14Feb13	MOB	GPL	MPFJ	Initial Drawing
Revision	Date	Drawn	Chk'd	App'd	Description

Safe Area Sentry P/N 8180281C "X"

Sentry Card Reader

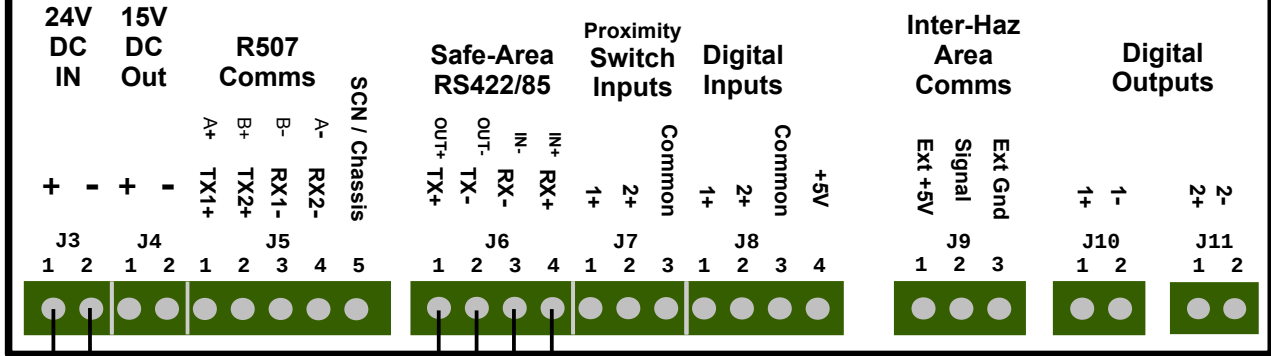

Safe Area

Sentry Card Reader

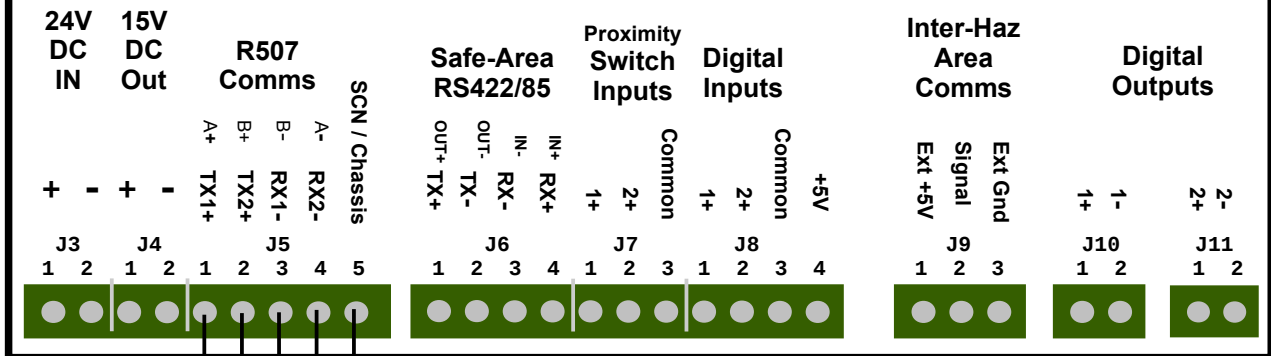

Hazardous Area

Note : Ensure RS-485 bus is correctly biased and terminated

R507 I.S. Interface Module

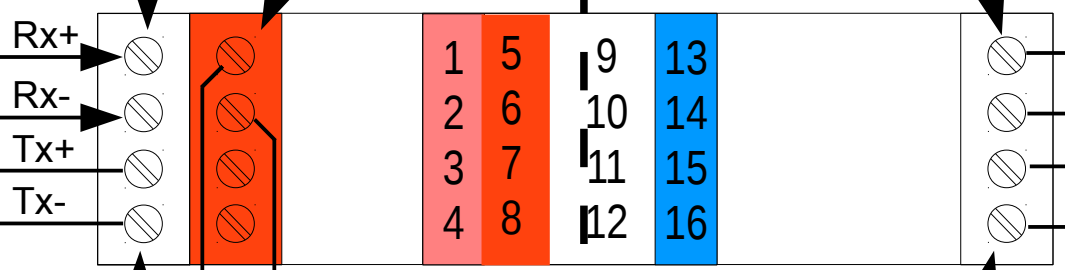

RS-485 Bus To Other Devices

Related Product Document
The QAN Responsible Person must Approve any Changes or ECNs

This drawing may not be reproduced without the consent of Mercury IMC Ltd
© Mercury IMC Ltd, 2008

Revision	Date	Drawn	Chk'd	App'd	Description
4					
3					
2					
1					
0	23Mar17	MPFJ	MOB	MOB	Initial Drawing

Specifications

Certification	Sira Certificate. No. 99ATEX2138X. Gas only variant: ATEX EEx ia IIC T4, Zone 0 Dust only variant: ATEX Ex tb IIIC T85°C, Zone 20 Gas & Dust variant: ATEX EEx ia IIC T4, Zone 0 ATEX Ex tb IIIC T85°C, Zone 20
Ambient temperature	-20°C to +60°C (operating), -40°C to +70°C (Storage).
Ingress protection	IP65 to EN 60529.
Enclosure	Powder coated painted aluminium alloy, Weight 1.7Kg, with EM reader. Static dissipative GRP, Weight 1.7Kg, with EM reader.
Supply voltage	20 to 32 Volts D.C. at approx 40mA (dependent on reader used).
Data protocol	Point-to-point and Multi-drop (based on VT-100), compatible with Mercury 2/2e/2+ Terminal. Modicon Modbus.
Card formats	A range of proximity cards, including EM4001 (or compatible), MIFARE, Hitag, AWID and a range of HID standard formats.
Proximity Inputs	2 Inputs characterised for direct connection to Namur proximity switches, utilising the 1.2mA/2.1mA switching levels. [Note: refer to J7 & J8 terminal characteristics on page 2 of the ATEX certificate for the safety description]
Digital Inputs	2 general purpose Digital Inputs. These are intended for direct connection to IS Simple Apparatus, such as a microswitch, but can be driven by an open-collector or a push-pull TTL output. [Note: refer to J7 & J8 terminal characteristics on page 2 of the ATEX certificate for the safety description]
Digital Outputs	2 opto-isolated Digital Outputs. These can sink 25mA and tolerate up to 28V. [Note: refer to J10 & J11 terminal characteristics on page 2 of the ATEX certificate for the safety description]
Multi-drop	Up to 32 Sentry card readers in normal multi-drop mode and 64 units in Modbus mode.
Baud rate	1200 to 19200 baud with the R507 barrier.
Mechanical	Height 122mm, Width 224mm, Depth 85mm.
Connections	IS version, 4-wire connection to R507 IS Interface Module (Non IS version*, 2-wire power and 2- or 4-wire communications)

Sentry Link Settings

Serial Output Mode

Link	Description
LK1	ON = EEPROM contents are protected OFF = EEPROM contents can be written (default)
LK2/3	Both ON = Wiegand Swipe Both OFF = Proximity Card
LK4	J9 Hazardous Area Comms Output Data Source 1-2 (RHS) = Normal operation (default) 2-3 (LHS) = Not used
LK5/6	Sets the configuration mode (see "Configuring the Sentry Card Reader")
LK7	Safe Area Receive Data Link ON = Safe Area RS485 OFF = IS communications (default)
LK8/9	When fitted enables +15V output source Default is OFF

Wiegand D1/D0 Output Mode

Link	Description
LK1	Wiegand Pulse Output Speed ON = Slow OFF = Fast
LK2/3	As per Serial Output Mode
LK4	Not used
LK5	ON = Recalculate start/stop parity bits OFF = Output existing start/stop parity bits
LK6	ON = Output lowest 32bits only OFF = Output all data bits
LK7	Not used
LK8/9	As per Serial Output Mode